

RoboAnalyser-based Online Competition 2021

TEAM NUMBER-C1

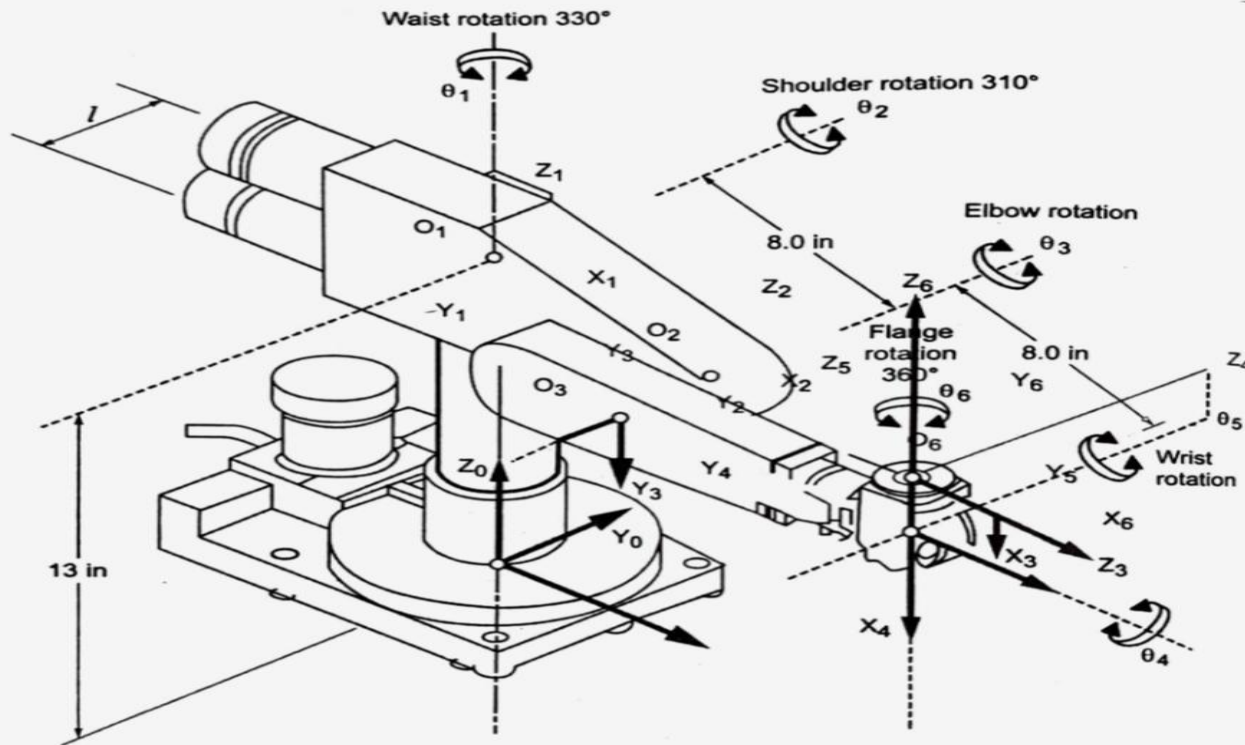

- ☆ Kishalay Raj
- ☆ Jigyashree Konwar
- ☆ Ankita Buragohain
- ☆ Bhaskarjyoti Pathak

We certify that this project was undertaken by us for the Roboanalyzer-based online competition (ROC)"conducted by Dr. Nayan M. Kakoty of Tezpur University in collaboration with Prof. S.K Saha of IIT Delhi and Mr. Rajeevlochan C.G. of Amrita Vishwa Vidyapeetham, Bengaluru Campus during May 01, 2021, to July 11, 2021.

Robot Motion

1. KINEMATICS :-

- Forward Kinematics

→ $P_{world} = (x, y, z)$

- Inverse Kinematics

→ $P_{joint} = (\theta_1, \theta_2, \theta_3)$

2. DYNAMICS

- Forward Dynamics

- Inverse Dynamics

☆ Two methods can be used in order to obtain the equations of motion:

→ (i) Newton-Euler formulation

Basic Equation:-

(a) $f = dm v/dt = ma$ & (b) $\tau_o = dl_o \omega_o/dt$

→ (ii) Lagrangian formulation

Basic Equation:- $L = K - P$

Task:

(i) To Execute Fkin of 3R Manipulator

(ii) Graphical Plot

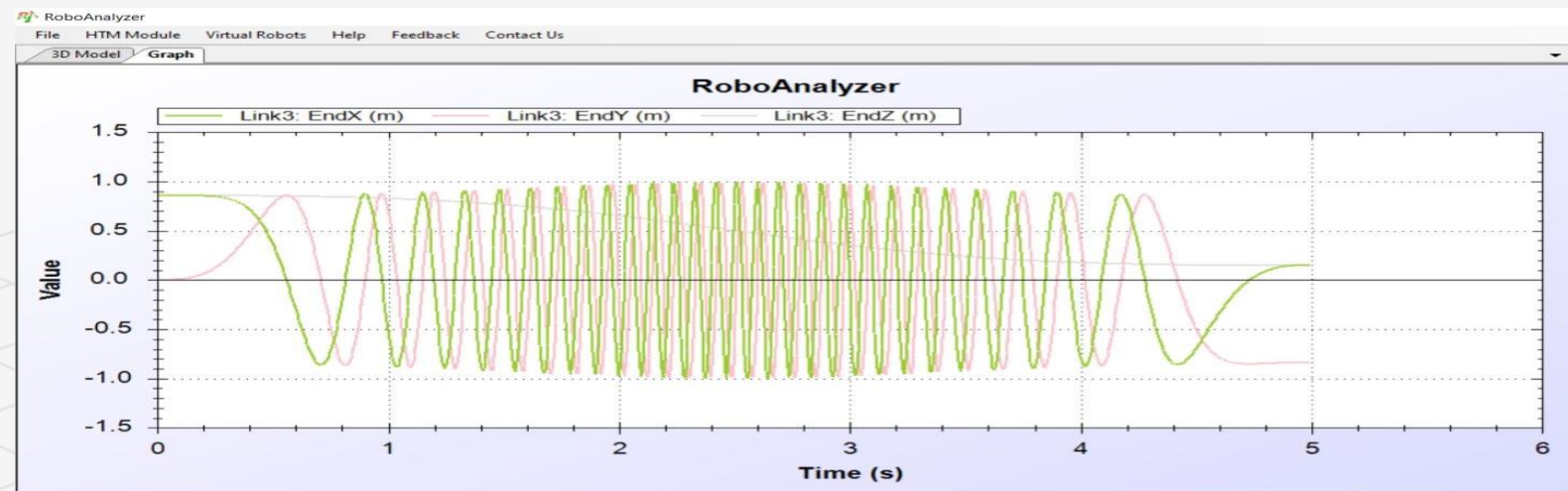
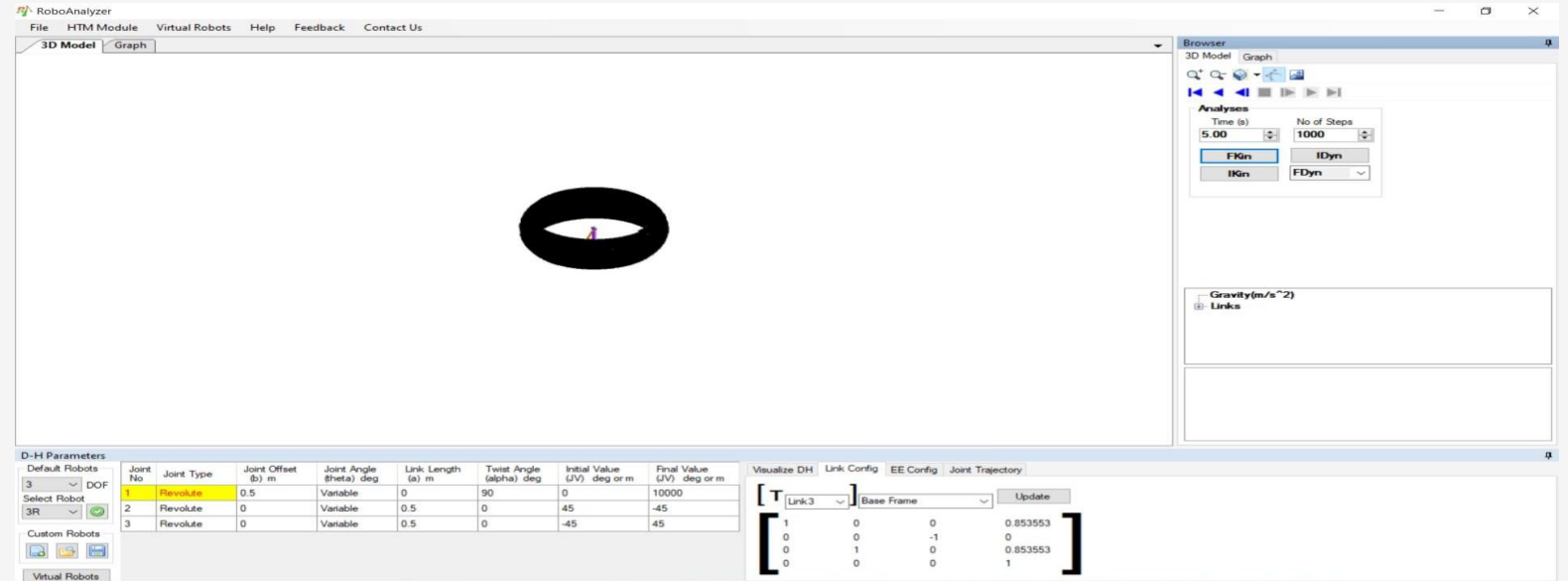

Procedure:-

Working Steps :-

- (i) In order to draw the trajectory of any object we used softwares like ANSYS APDL, AutoCad, and Matlab. After that, from these softwares, we export solution data into Excel Sheet.
- (ii) Thus we get values of X, Y & Z Coordinates into the Excel file. We do some modification in it to draw a specific trajectory/Name/Action/Artistic Shape in RoboAnalyzer.

Task:- To draw a Cantilever Beam

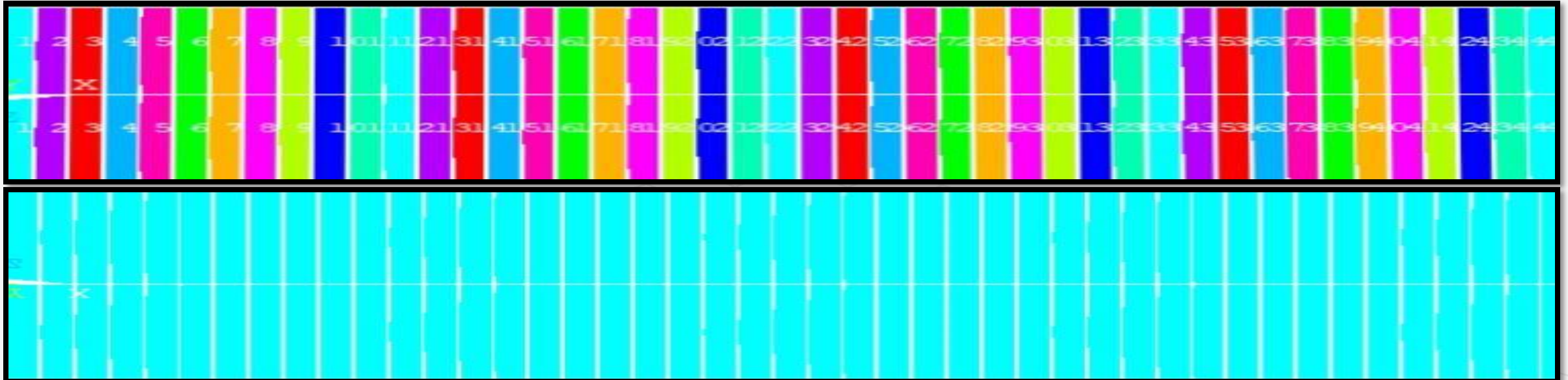

A	B	C	D	E	F
0	90	0	-180	270	0
0	89.78779	0.212207	-180	270	0
0	89.5754	0.425299	-180	270.0007	0
0	89.36282	0.639295	-180	270.0021	0
0	89.15006	0.854171	-180	270.0042	0
0	88.9371	1.069954	-180	270.0071	0
0	88.72394	1.286646	-180	270.0106	0
0	88.51059	1.504247	-180	270.0148	0
0	88.29702	1.722778	-180	270.0198	0
0	88.08325	1.942224	-180	270.0255	0
0	87.86926	2.162612	-180	270.0319	0
0	87.65506	2.383932	-180	270.039	0
0	87.44064	2.606201	-180	270.0468	0
0	87.22599	2.829417	-180	270.0554	0
0	87.0111	3.053602	-180	270.0647	0
0	86.79599	3.27875	-180	270.0747	0
0	86.58064	3.504861	-180	270.0855	0
0	86.36505	3.731949	-180	270.097	0
0	86.14922	3.960024	-180	270.1092	0
0	85.93313	4.189099	-180	270.1222	0
0	85.71678	4.419167	-180	270.136	0
0	85.50018	4.650241	-180	270.1504	0
0	85.28331	4.882333	-180	270.1656	0
0	85.06617	5.115445	-180	270.1816	0
0	84.84876	5.349592	-180	270.1984	0
0	84.63108	5.584764	-180	270.2158	0
0	84.4131	5.820985	-180	270.2341	0
0	84.19484	6.058271	-180	270.2531	0
0	83.97628	6.296615	-180	270.2729	0

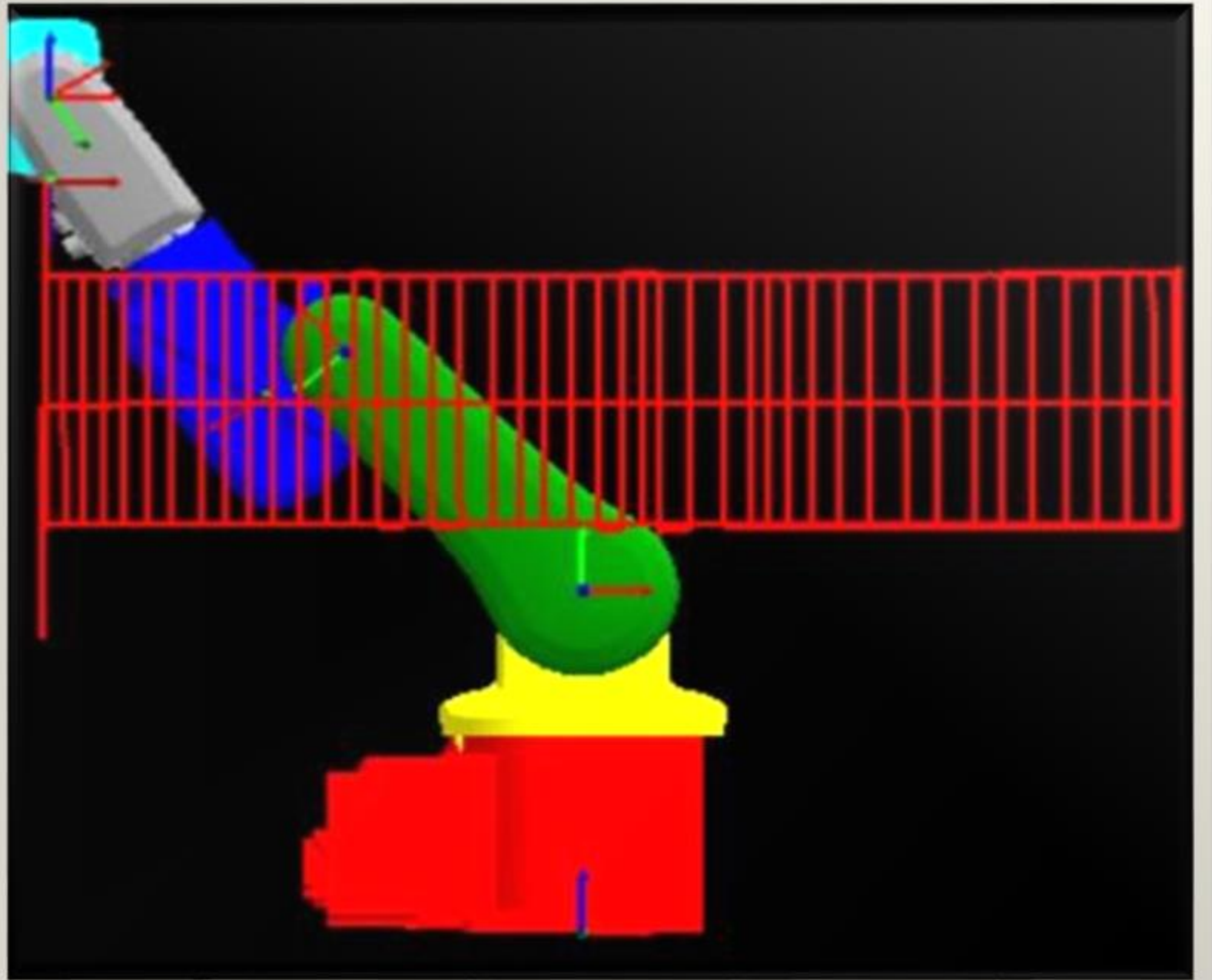

Task :- To draw a Robot Shape

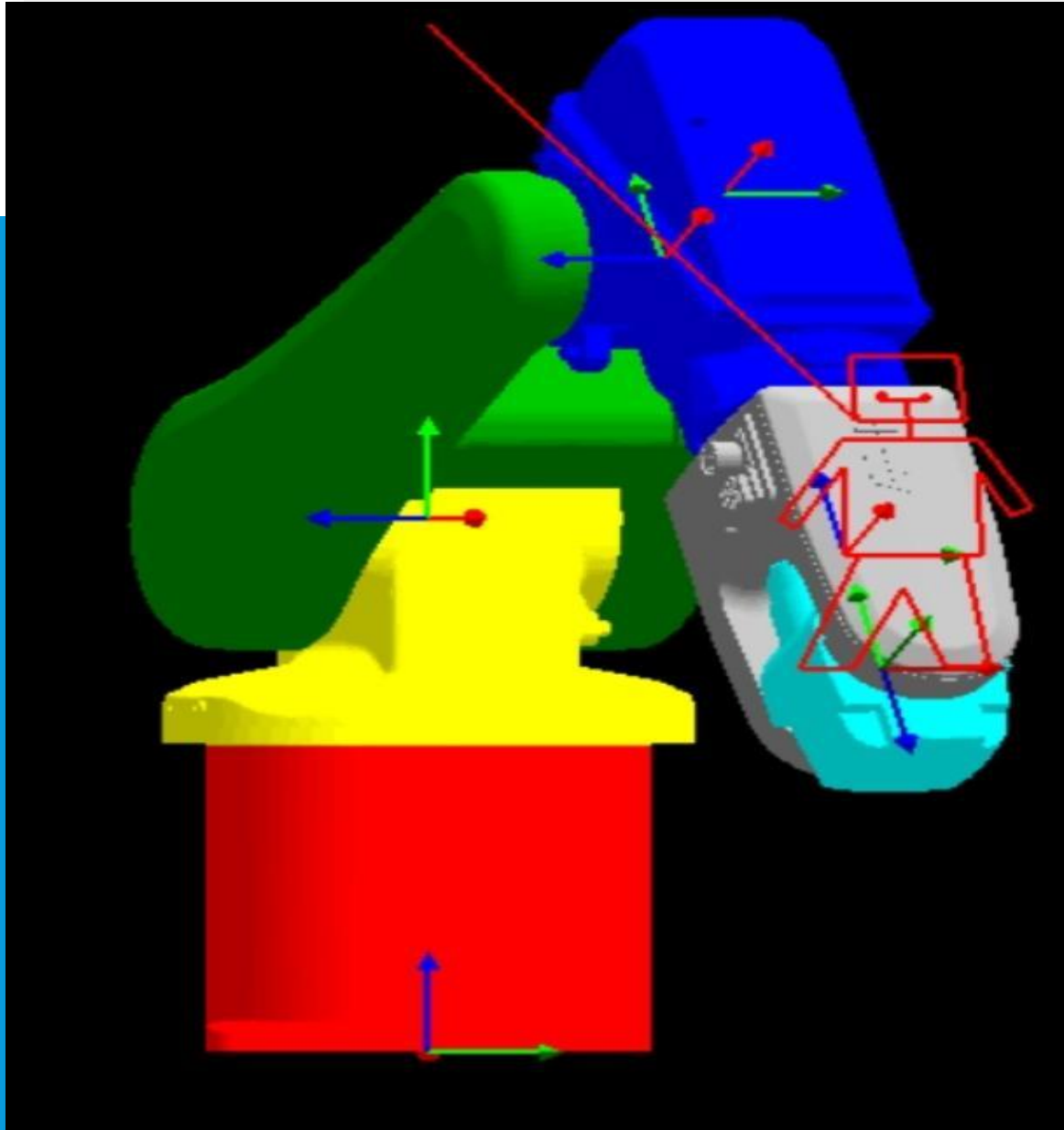

Task : To write name of Team Members



Task:- Artistic Shapes Created by Us



Clay Pot

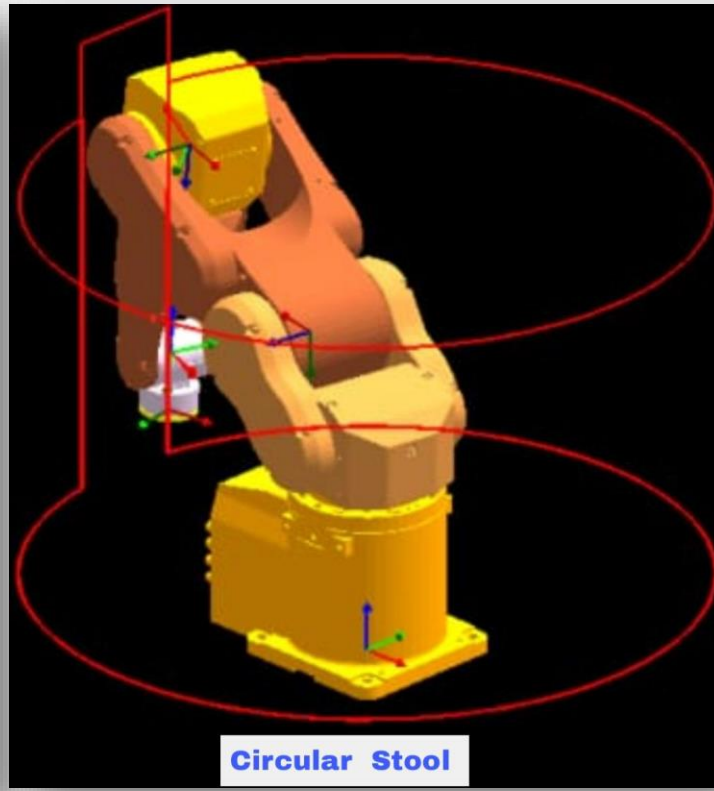

Circular Stool



Glass



THANK YOU